

MAINTENANCE MADE EASY



Superior Products & Support for the Swimming Pool & Spa Service Professional

ROLA-CHEM[®]

Rola-Chem.com | 800-549-4473

ROLA-CHEM®

A PREFERRED CHOICE OF COMMERCIAL POOL AND SPA MAINTENANCE PROFESSIONALS SINCE 1964



Your Customers Want One Thing: The Perfect Pool

At Rola-Chem, helping pool maintenance professionals achieve the Perfect Pool is in our DNA. From precise chemical feeding to advanced control and monitoring, our products are engineered for optimal efficiency and ease-of-use. We understand that water quality systems that are easier-to-use and consistent will help you exceed customer's expectations, grow your business and increase profit.

ROLA-CHEM IS MAINTENANCE MADE EASY

Our goal is to make maintenance easier for pool and spa service professionals. We are your trusted source for reliable equipment that will save you time and money and allow your customers to spend more time enjoying their investment.

Pool Professionals Tell Us That Maintenance is Made Easier...

- When system equipment is intuitive and works
- When system components needed can be sourced from one company, ordered with a single part number and trained professionals are available via call or online chat
- When complete systems can be easily installed and set up right from the box
- When set up can be achieved without manuals
- When little technical expertise is needed
- When troubleshooting and support videos are hosted on YouTube
- When all you need is the electrical, tanks, and space to hang a fully integrated, Ready-to-Mount System—no complicated instructions
- When your customer can spend 60% less time monitoring and managing pool and spa water quality then with other methods

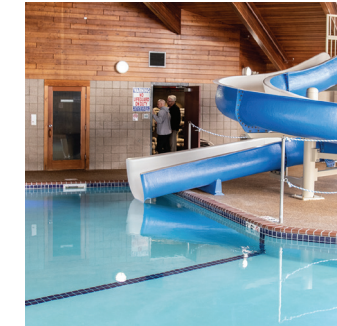

A LEGACY OF INNOVATION

For over fifty years Rola-Chem has relied on the expertise and best practices of certified pool service professionals to achieve the perfect pool. From large pool service companies to small owner-operated businesses, the Rola-Chem brand has remained true to its roots and remains focused solely on pool water quality systems in both commercial and residential installations. At the core of our success is the reliable Rola-Chem peristaltic pump. While the basic function of our pump/controller systems remains the same (programmed chemical dosing and monitoring), our products have evolved as technology has advanced. Our ability to provide consistent improvements to our systems would not be possible without feedback from you, the Pool Service Pro.



"Because Rola-Chem is so reliable and easy-to-use, I can serve more customers and make more money."

Hector Munoz—HDM Pools

WARNING: This product can expose you to chemicals which are known to the state of California to cause cancer and/or reproductive harm. For more information go to www.P65Warnings.ca.gov

For detailed compliance information on specific products, please contact compliance@specialtyvmfg.com

WHAT'S NEW?

This catalog presents several new ways that Maintenance is Made Easy by Rola-Chem:

- The New PRO Series 300 Feeder
- The New 555XXP Generation II Digital FAC pH/Dual ORP/FAC (ppm) controller
- 8 new Ready-to-Mount Systems
- Links to Installation and How-to videos



Pool Pros Coast to Coast—Pro tips to simplify your Job

TABLE OF CONTENTS

Peristaltic Pumps Pro Series 300	3-4
Ready-to-Mount Systems.....	5-7
Interlock / Mobile App.....	8
Control Systems Diagrams	9
Flow Meters	10
Professional System Components.....	11-12
Chemical Tanks.....	13
Pool Maintenance Made Easy	14

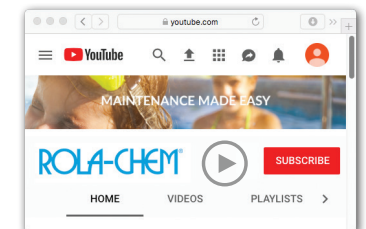

Maintenance is made easier with our YouTube video library. From installation and set-up to trouble shooting, help with Rola-Chem equipment is a click away.



SCAN ME

NEW! THE PRO SERIES 300 PERISTALTIC PUMPS

The **NEW PRO Series 300 Peristaltic Pumps** maintain the best of the Rola-Chem Pro Series legacy* while improving primary function and simplifying set up.



MODEL SHOWN : RC305MC
P/N 543818
UPC 7-57706 00038-3

Three-Roller Operation

*Mounting patterns and many parts interchange with legacy Pro Series models.



MODEL SHOWN: RC301MC
P/N 543807
UPC 7-57706 00027-7

Two-Roller Operation
(1) GPD Pump Only

ALL ROLA-CHEM PUMPS ARE NSF c UL US LISTED

ESTIMATED FEED RATES

AT GIVEN TIMER SETTINGS – GALLONS PER DAY

SETTING %	ON TIME	OFF TIME	RC301	RC303	RC305	RC307
1	5.4 SEC	8.9 MIN	—	0.12	0.38	0.77
2	10.8 SEC	8.8 MIN	0.02	0.24	0.76	1.54
3	16.2 SEC	8.7 MIN	0.03	0.36	1.14	2.31
4	21.6 SEC	8.6 MIN	0.04	0.48	1.52	3.08
5	27.0 SEC	8.6 MIN	0.05	0.60	1.90	3.85
6	32.4 SEC	8.5 MIN	0.05	0.72	2.28	4.62
7	37.8 SEC	8.4 MIN	0.06	0.84	2.66	5.39
8	43.2 SEC	8.3 MIN	0.07	0.96	3.04	6.16
9	48.6 SEC	8.2 MIN	0.08	1.08	3.42	6.93
10	54.0 SEC	8.1 MIN	0.09	1.20	3.80	7.70
15	1.4 MIN	7.7 MIN	0.14	1.80	5.70	11.55
20	1.8 MIN	7.2 MIN	0.18	2.40	7.60	15.40
25	2.3 MIN	6.8 MIN	0.23	3.00	9.50	19.25
30	2.7 MIN	6.3 MIN	0.27	3.60	11.40	23.10
35	3.2 MIN	5.9 MIN	0.32	4.20	13.30	26.95
40	3.6 MIN	5.4 MIN	0.36	4.80	15.20	30.80
45	4.1 MIN	5.0 MIN	0.41	5.40	17.10	34.65
50	4.5 MIN	4.5 MIN	0.45	6.00	19.00	38.50
55	5.0 MIN	4.1 MIN	0.50	6.60	20.90	42.35
60	5.4 MIN	3.6 MIN	0.54	7.20	22.80	46.20
65	5.9 MIN	3.2 MIN	0.59	7.80	24.70	50.05
70	6.3 MIN	2.7 MIN	0.63	8.40	26.60	53.90
75	6.8 MIN	2.3 MIN	0.68	9.00	28.50	57.75
80	7.2 MIN	1.8 MIN	0.72	9.60	30.40	61.60
85	7.7 MIN	1.4 MIN	0.77	10.20	32.30	65.45
90	8.1 MIN	54.0 SEC	0.81	10.80	34.20	69.30
95	8.6 MIN	27.0 SEC	0.86	11.40	36.10	73.15
99	8.9 MIN	5.4 SEC	0.89	11.88	37.62	76.23
On	CONTINUOUS		0.90	12.00	38.00	77.0



"Consistently tracking and maintaining proper pH and sanitizer levels is very important for the safety of swimmers and is also vital to the longevity of operating equipment. The 555XXP controller from Rola-Chem tracks pH and sanitizer consistently and rarely requires recalibration, this is big time saver for us."

John Sims—Blue Marlin Pool Services

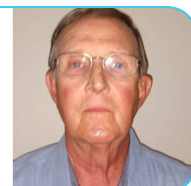

THE PRO SERIES 300 PERISTALTIC PUMPS FEATURE:

- New commercial design
- Fully digital timer
- Refined dosing increments—for more precise control
- New, more versatile mounting options
- Other features include: quick-release cover for fast tubing access, three-way switch controls timer/off/continuous, self-priming pump and clear Tygon and Black Norprene Squeeze Tubes
- The Pro Series 300 retains a 30psi rating and versatile 18-ft. suction lift.
- Pumps operate on 9-minute cycles and are available in 120V or 240V corded or permanent wire configurations with maximum amps—2.5

SEE ROLA-CHEM.COM FOR THE COMPLETE LIST OF PRO SERIES 300 MODELS

ROLA-CHEM PRO SERIES OUTPUT – TIMER MODE

PRO SERIES 300 MODEL	LEGACY SERIES MODEL	MINIMUM FEED RATE/24HR	MAXIMUM FEED RATE/24HR	RECOMMENDED VOLUME OF SPA WATER TO BE TREATED (GALLONS)*	RECOMMENDED VOLUME OF POOL WATER TO BE TREATED (GALLONS)*	MAX. VOLUME OF WATER TO BE TREATED (GALLONS) - PER CALIFORNIA BUILDING CODE TITLE 24
RC-301	RC-252 SC	.01 GPD	.9 GPD	500–2,500	2,500–5,000	3,000
RC-303	RC-25/53 SC	.12 GPD	12 GPD	2,500–25,000	5,000–65,000	40,000
RC-305	RC-103 SC	.38 GPD	38 GPD	—	65,000–200,000	127,000
RC-307	RC-503 SC	.75 GPD	77 GPD	—	180,000–400,000	257,000

GPD = GALLONS PER DAY *USING 12.5% LIQUID CHLORINE

OUTPUT FOR DIGITAL CONTROLLER APPLICATIONS

	ROLA-CHEM PRO SERIES OUTPUT	RECOMMENDED VOLUME SPA	RECOMMENDED VOLUME POOL
RC-301	.08 Ounces Per Minute	Not Recommended	Not Recommended
RC-303	1.06 Ounces Per Minute	500 to 2,000 Gallons	Up to 30,000 Gallons
RC-305	3.37 Ounces Per Minute	2,000 to 5,000 Gallons	Up to 80,000 Gallons
RC-307	6.84 Ounces Per Minute	5,000 to 12,000 Gallons	80,000 Plus Gallons

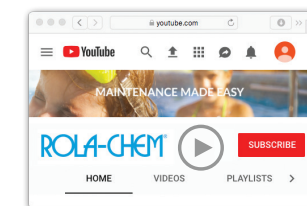

youtube.com/user/inforolachem

NEW! MODEL 555XXP GENERATION II DIGITAL FAC pH/Dual ORP/FAC (ppm) CONTROLLER

555XXP Microprocessor-based chemical automation system—which continuously monitors the pH and sanitizer level in a pool or spa. Dual ORP to control two sanitizers.



MODEL SHOWN: RC555XXP
Digital pH/Dual ORP/FAC (ppm) Controller

Used to Control Two Sanitizer Sources

P/N 555000
UPC 7-5770 600310-0

	pH	ORP 1	ORP 2	Feed Cycle
Factory Setting	7.4	650 mV	640 mV	10 Seconds
Display Range	6.8–8.4	0–995 mV	0–995 mV	
Setpoint Range	7.0–8.0	400–900 mV	400–900 mV	
Feed Cycles	.6 to 900 seconds w/ 5-minute analyzation periods			
Power	120V corded (input/output)			
Feed	Timed or Continuous			
Maximum Output	3.15 Amps			

INCLUDES: Controller, flow cell with flow switch, probes, 3/8" tubing and fittings.

ALL ROLA-CHEM CONTROLLERS ARE NSF ANSI CERTIFIED

555XXP Features:

- Display and record Free Available Chlorine (ppm)
- Free web-based monitoring—logs and displays ORP/FAC (ppm). Ethernet Connection Included
- Digital readouts—pH/Dual ORP/FAC (ppm)
- Timed or continuous feed setting
- Acid or base feed
- Dip switch programmable settings
- Built-in out-of-range safety timeouts

NEW! MODEL 555XXP READY-TO-MOUNT SYSTEMS

ALL COMPONENTS REQUIRED FOR POOL AUTOMATION MOUNTED ON A POLYPROPYLENE BOARD

MODEL SHOWN: 555007
UPC 7-57706 00311-7

Control Two Sanitizer Sources with Digital pH/Dual ORP System



INCLUDES: Programmable Digital pH/Dual ORP Controller complete with Flow Cell, Flow Switch, Sample Valves, ORP and pH Probes, 40' of Black 3/8" Tubing, 100' Clear 7/16" Tubing and Fittings, two Peristaltic Pumps (38 GPD), In-line Flow Cell Strainer.

Also Available:

- 555008** UPC 7-5770600312-4 Includes one **12 GPD** Peristaltic Pump and one **38 GPD** Peristaltic Pump
- 555010** UPC 7-5770600314-8 Includes two **12 GPD** Peristaltic Pumps
- 555012** UPC 7-5770600316-2 Includes one **12 GPD** Peristaltic Pump and one **Solenoid Kit**
- 555013** UPC 7-5770600317-9 Includes one **12 GPD** Peristaltic Pump (Gold Tip ORP Probe)
- 555014** UPC 7-5770600318-6 Includes two **77 GPD** Peristaltic Pumps
- 555015** UPC 7-5770600319-3 Includes one **38 GPD** Peristaltic Pump and one **Solenoid Kit**
- 555016** UPC 7-5770600320-9 Includes one **38 GPD** Peristaltic Pump (Gold Tip ORP Probe)
- 555017** UPC 7-5770600321-6 Includes one **38 GPD** Peristaltic Pump and one **77 GPD** Peristaltic Pump

MODEL 554XP GENERATION II DIGITAL CONTROLLERS



MODEL SHOWN: RC554XP
Digital pH/ORP Controller

P/N 554000
UPC 7-57706 00136-6

	pH	ORP	Feed Cycle
Factory Setting	7.4	650 mV	.6 Seconds
Display Range	6.8–8.2	0–995 mV	
Setpoint Range	7.0–8.0	400–900 mV	
Feed Cycles	.6 to 900 seconds w/ 5-minute analyzation periods		
Power	120V corded (input/output)		
Feed	Timed or Continuous		
Maximum Output	5 Amps		

INCLUDES: Controller, flow cell with flow switch, probes, 3/8" tubing and fittings.

ALL ROLA-CHEM CONTROLLERS ARE NSF ANSI CERTIFIED

Digital pH/ORP Controllers Feature:

- Digital readouts
- ORP technology
- Redox sensor
- Dip switch programmable settings
- Timed or continuous feed settings
- Built-in out-of-range safety timeouts
- pH calibration
- Acid or base feed
- Microprocessor logic
- Globe flow cell with flow switch
- Compatible with most peristaltic pumps
- Can also be used with erosion feeder/solenoid applications

MANUFACTURED IN THE USA

MODEL 554XP READY-TO-MOUNT SYSTEMS

ALL COMPONENTS REQUIRED FOR POOL AUTOMATION MOUNTED ON A POLYPROPYLENE BOARD

MODEL SHOWN: 554500
UPC 7-57706 00116-8

pH Liquid Acid/ORP Liquid Chlorine System



INCLUDES: Programmable Digital pH/ORP Controller complete with Flow Cell, Flow Switch, Sample Valves, ORP and pH Probes, 40' of Black 3/8" Tubing, 100' Clear 7/16" Tubing and Fittings, two Pro Series 300 Peristaltic Pumps (38 GPD), In-line Flow Cell Strainer.

Also Available:

- 554501** UPC 7-57706 00117-5 Includes one **38 GPD** & one **12 GPD** Peristaltic Pump
- 554503** UPC 7-57706 00119-9 Includes two **12 GPD** Peristaltic Pumps
- 554508** UPC 7-57706 00123-6 Includes two **77 GPD** Peristaltic Pumps
- 554512** UPC 7-57706 00126-7 includes one **77 GPD** & one **38 GPD** Peristaltic Pump

MODEL 554XP READY-TO-MOUNT CONTROLLER SYSTEMS

ALL COMPONENTS REQUIRED FOR POOL AUTOMATION MOUNTED ON A POLYPROPYLENE BOARD

MODEL SHOWN: 554510
UPC 7-57706 00124-3
pH/ORP Erosion Feeder System

INCLUDES: Programmable Digital pH/ORP Controller complete with Flow Cell, Flow Switch, Sample Valves, ORP and pH Probes, 40' of Black 3/8" Tubing, 100' Clear 7/16" Tubing and Fittings, one Peristaltic Pump (38 GPD), 120 volt Solenoid Kit (includes Solenoid, In-line filter and Check Valve), In-line Flow Cell Strainer.

Erosion Feeder NOT included.

Also Available:
554505 UPC 7-57706 00121-2
Includes one **12 GPD** Peristaltic Pump and one Solenoid Kit

MODEL 554511
UPC 7-57706 00125-0
pH/ORP Salt Generator System

INCLUDES: Programmable Digital pH/ORP Controller complete with Flow Cell, Flow Switch, Sample Valves, ORP and pH Probes, 40' of Black 3/8" Tubing, 100' Clear 7/16" Tubing and Fittings, one Peristaltic Pump (38 GPD), In-line Flow Cell Strainer.

Power output to Salt Generator (not included) is 110 Volt 5 Amp

Also Available:
554506 UPC 7-57706 00122-9
Includes one **12 GPD** Peristaltic Pump
Rola-Chem Solenoid Kit 550300 is rated for 3–230 psi and has a valve coefficient of (Cv) 4.9.



550300 1/2"
UPC 7-5770600305-6
Solenoid Kit



MODEL RC54M
Controller Remote Monitor
P/N 554400
UPC 7-57706 00147-2

- Monitor is compatible with Rola-Chem Generation II Digital pH/ORP Controllers: RC554XP (manufactured after October 2015) and RC554XXP (manufactured after May 2016)
- Monitor will upload controller data at specific intervals that are set by operator

- Secure website with operator set password
- Serial connection cable from monitor to data port of controller is included
- A hardwired ethernet connection with unrestricted internet access must be available
- LED lights verify connection to local network (Green) and activity (Amber)
- Internal reset button—used to reconnect monitor to server
- Power down will automatically reconnect monitor to server
- No subscription required

5-YEAR LIMITED WARRANTY ON CONTROLLER ELECTRONICS. 1-YEAR LIMITED WARRANTY ON PROBES, FLOW CELL AND VALVE.
NOTE: It is recommended that an in-line filter system (part number 550591) be used before the flow cell.

NEW! INTERLOCK PRESSURE SWITCH
Maximize Protection From Chemical Exposure

- Works to prevent harmful chemicals from being pumped into the circulation line
- Acts as a secondary control system to shut power off to the controller should there be a malfunction, bringing its operations to a halt
- Compatible with any automated chemical controller system



Features:

- Adjustable minimum pressure requirement (1.0-6.0 PSI)
- Simple installation process—plugs into any GFCI outlet
- Factory pre-set at 3 PSI
- All components are UL listed

ALL ROLA-CHEM CONTROLLERS ARE NSF ANSI CERTIFIED

MODEL SHOWN:
ITEM #550311

	RANGE	MAX
Pressure Port	1 – 6 PSI	X
Output	125 VAC	10 Amp
Input	125 VAC	X

INCLUDES: Switch, box, tubing and fittings—compact and ready for installation; designated input / output plugs; descriptive label with user-friendly guidance.

NEW! MOBILE APP
For Efficient Installation

Head to the App Store to download our FREE app for easy access to resources that can assist with the fast and successful installation of essential maintenance products like our new Pressure Switch

Visit our website: www.rola-chem.com

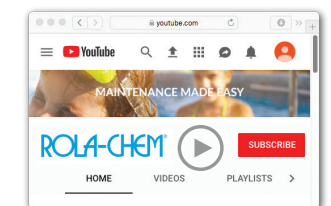

 "A Rola-Chem Ready-To-Mount system installation requires very little technical expertise. Most customers can be guided on system set up questions over the phone I can't say that about any other manufacturer's system."
Mike Volkers, CFP—Horizon Pool Supply

Liquid System

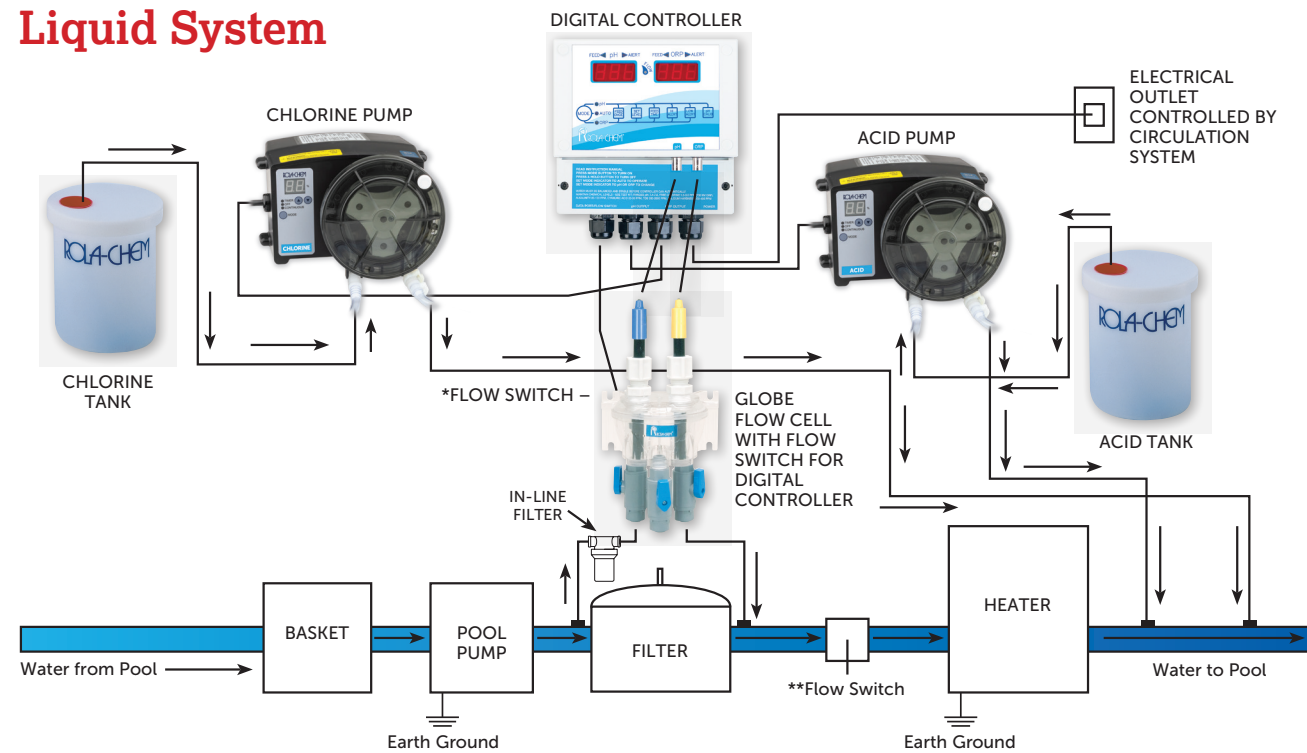

*Flow switch to ensure circulation to control probes and indication that pool circulation is occurring (included in Digital Controller/Globe Flow Cell Only)

**Safety flow Switch for protection of heater and to ensure dilution of chemical into the pool

Erosion System

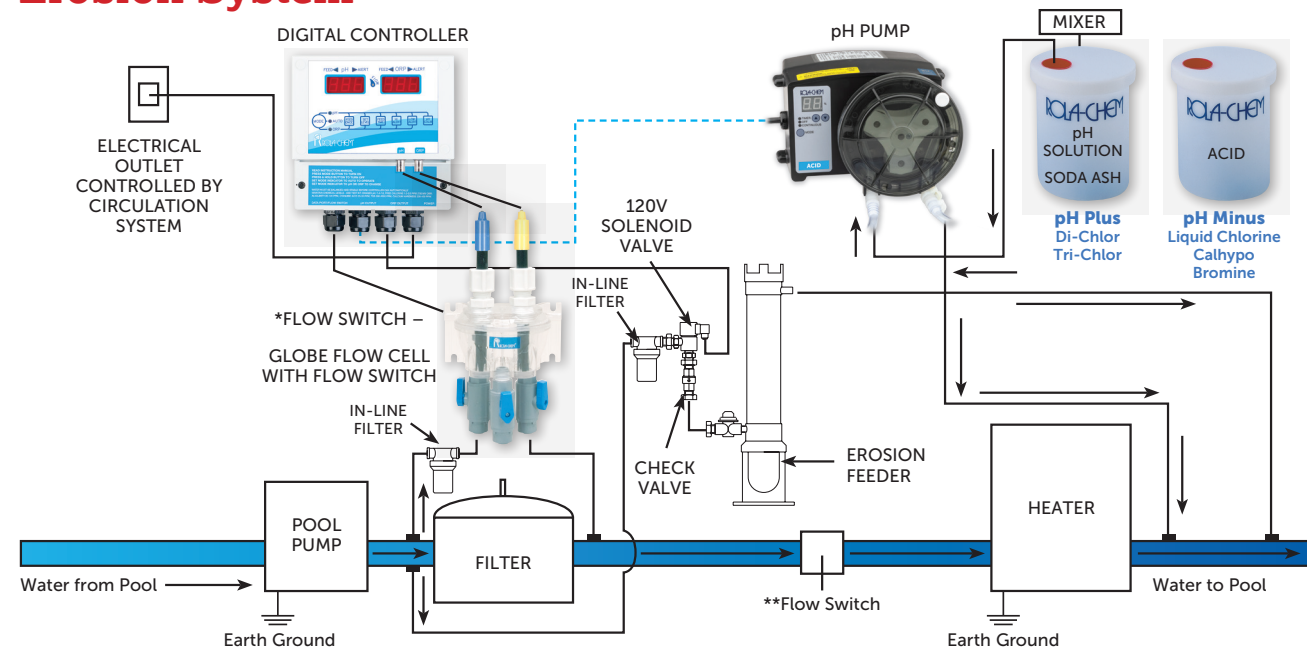

*Flow switch to ensure circulation to control probes and indication that pool circulation is occurring (included in Digital Controller/Globe Flow Cell Only)

**Safety flow Switch for protection of heater and to ensure dilution of chemical into the pool

Rola-Chem Solenoid Kit 550300 is rated for 3–230 psi and has a valve coefficient of (Cv) 4.9.

NO MORE CLOGGED FLOWMETERS!
 ROLA-CHEM'S FLOWMETERS HAVE A WIDE CHAMBER THAT GREATLY REDUCES MINERAL DEPOSITS BY ALLOWING HIGHER FLOW VOLUME

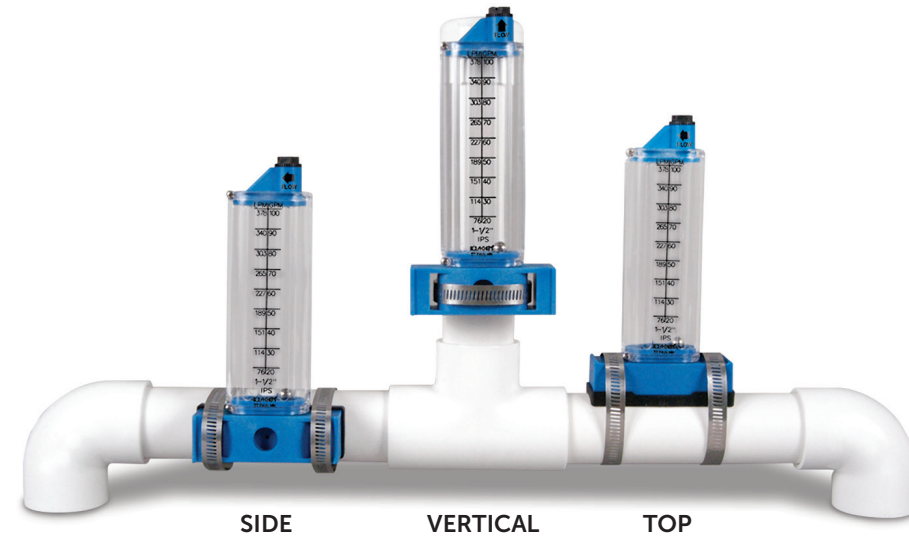

ACCURATE READINGS

- Our heavy-duty gasket ensures airtight seals

VISUAL INDICATOR

- Calibrated on both sides in gallons and liters per minute

SERVICABLE

- Easily open and remove calcium deposits if necessary

FULL RANGE MOUNTING

- Side, vertical, or top 1" to 8"; please specify when ordering. Vertical mount is reversible for up or down reading.
- Requires 3/4" diameter hole in pipe

EASY-TO-READ BOBBIN

- 316 stainless steel ball prevents corrosion

Designed to be compatible with practically every existing flowmeter, replace your old clogged flowmeters with these accurate, easily serviced units from Rola-Chem.

Rola-Chem flowmeters are built to withstand water temperatures up to 200°F and are manufactured to work with schedule 40 PVC pipe.

Easy-to-Use Vertical Mount Gaskets for Nine PVC Pipe Sizes



FLOW METER SIZING GUIDE

MODEL NO.	PIPE MATERIAL	PIPE SIZE	A* MINIMUM	B* MINIMUM	RANGE GPM	RANGE LPM	CLAMP SIZE
570321	PVC-GALV	1"	5"	10"	10–30	38–114	40
570331	PVC-GALV	1.25"	6"	11"	15–50	57–189	44
570340	COPPER	1.5"	8"	15"	20–55	76–208	44
570341	PVC-GALV	1.5"	8"	15"	25–60	95–227	44
570350	COPPER	2"	10"	20"	40–140	151–530	56
570351	PVC-GALV	2"	10"	20"	40–140	151–530	56
570360	COPPER	2.5"	13"	25"	70–245	265–927	64
570361	PVC-GALV	2.5"	13"	25"	70–240	265–908	64
570370	COPPER	3"	15"	30"	100–280	379–1060	64
570371	PVC-GALV	3"	15"	30"	100–300	379–1136	64
570380	COPPER	4"	20"	40"	200–480	757–1816	44 (2)
570381	PVC-GALV	4"	20"	40"	175–500	662–1893	44 (2)
570391	PVC-GALV	6"	30"	60"	400–1050	1514–3975	64 (2)
570401	PVC-GALV	8"	40"	80"	700–1900	2650–7192	72 (2)

*A = Minimum distance from downstream elbow or restriction. **B = Minimum distance from upstream elbow or restriction. After Part Number, Indicate Mounting: (T) = Top • (S) = Side • (V) = Vertical

PROFESSIONAL SYSTEM COMPONENTS

550300
1/2" Solenoid Kit



Rated for 3-230 psi—Coefficient (cv) 4.9

550180
Globe Flow Cell



Made from high-impact acrylic with Flow Switch

- For Digital Controller Systems

550135
8' pH Heavy-Duty Probe

550208
3' pH Heavy-Duty Probe

550136
8' ORP Heavy-Duty Probe

550209
3' ORP Heavy-Duty Probe



- For Digital & Analog Controller System

550201
ORP Gold Tip Probe



- Recommended for use with Chlorine (Salt) Generators

550089
Probe Replacement Fitting



- For Flow Cells

7125190
Quick Connect Valve



3/8" Tubing x 1/4" MNPT

- For Flow Cells

550193
Tubing Connectors



3/8" Tubing x 1/4" MNPT

550225
Black Tubing



3/8" x 40' Length



"My customers rely on their Rola-Chem's because they just work!"

Joe Dettrey—
Commercial Pool Supplies



PROFESSIONAL SYSTEM COMPONENTS

523400
Tri-Roller



523114
Norprene Hose
Black



523115
Tygon Hose



523255
Norprene/PE Assembly



550592 (Small) or 550591 (Large)
Inline Strainer Kit



Hose Assemblies

523140
Norprene/Vinyl



523118
Tygon/Vinyl



Check Valves

521160
3/8" Hose Barb x 3/8" Hose Barb



521170
3/8" Hose Barb x 1/4" MNPT



Injectors

527158
1/2" NPT x 7/16" OD Tube



520113
1/4" NPT x 3/8" OD Barb



527159
1/2" NPT x 7/16" OD Tube



520116
Vinyl Tubing 100'



520124
Yellow Chlorine Tubing 100'



520125
Pink Acid Tubing 100'



5/16" ID x 7/16" OD — For 3/8" O.D. Hose Barb

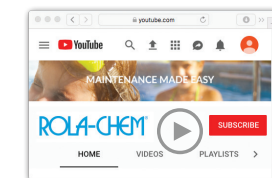

[youtube.com/user/inforolachem](https://www.youtube.com/user/inforolachem)

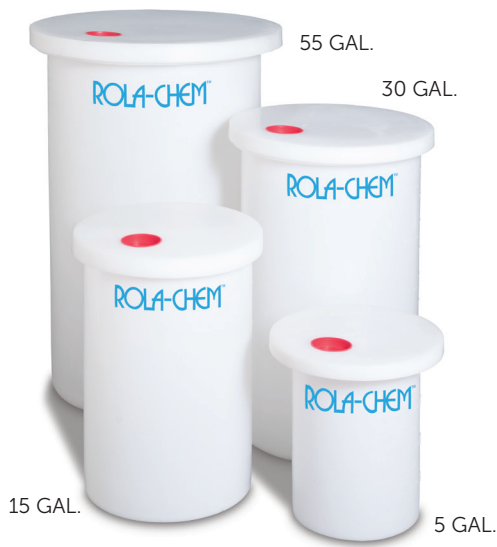

CHEMICAL TANKS

Rola-Chem offers a range of heavy duty tanks and covers available in 5, 15, 30, and 55 gallon sizes. Precision mold-ed of high-density polyethylene polymer, which is highly resistant to corrosive solutions.

Chemical Tanks Feature:

- Heavy Duty Construction—formed from high-density polyethylene
- Translucent - allows visual check of chemical level
- UV Protected - solar rays will not damage chemicals

PART NO.	PRODUCT DESCRIPTION	CAPACITY	HT.	DIA.	WT.
561405	Tank/Cover/Plug - 5 Gallon	5 Gallon	15.5"	15"	6#
561415	Tank/Cover/Plug - 15 Gallon	15 Gallon	23"	17"	15#
561430	Tank/Cover/Plug - 30 Gallon	30 Gallon	30"	20"	21#
561455	Tank/Cover/Plug - 55 Gallon	55 Gallon	38"	27"	22#
561265	System Tank*	15 Gallon	36.75"	15"	17#

SYSTEM TANK

System Tanks Feature:

- Convenient mounting of your Rola-Chem Pump on tank
- Includes chemical refill and pick-up holes
- Heavy Duty Construction—formed from high-density polyethylene
- Translucent—allows visual check of chemical level
- UV Protected—solar rays will not damage chemicals

543853 UPC 7-57706 00281-3
RC305MC Rola-Chem Pro Series 300 Pump 120 volt 38 GPD mounted on a 15-Gallon Poly Tank

543854 UPC 7-57706 00282-0
RC303MC Rola-Chem Pro Series 300 Pump 120 volt 12 GPD mounted on a 15-Gallon Poly Tank

543857 UPC 7-57706 00324-07
RC303MP Rola-Chem Pro Series 300 Pump 240 volt 12 GPD mounted on a 15-Gallon Poly Tank



*15 GAL. ONLY
(Pump not included)

SEE THESE AND OTHER "MAINTENANCE MADE EASY" PRODUCTS AT ROLA-CHEM.COM



SPA VAC
Self-contained spa and pool vacuum—extends to over 7 feet



ULTRA SCREEN
Catches debris and extends filter life



SCUMBUG
Removes scum line, devours grime and oils

POOL SENTRY
Maintains water level, protecting pumps against burnout



MAINTENANCE MADE EASY

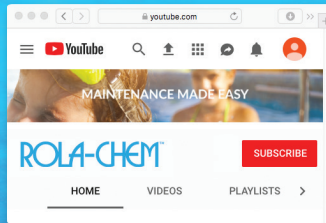

Maintenance is made easier with our YouTube video library, from installation and set-up to trouble shooting. Help with Rola-Chem equipment is a click away. [youtube.com/user/inforolachem](https://www.youtube.com/user/inforolachem)

ROLA-CHEM®

Rola-Chem.com | 800-549-4473

5858 Centerville Rd • St. Paul, MN 55127 | Local: 651-653-5031 • Fax: 651-653-0989 | info@Rola-Chem.com

